

YUPITERU

Multi-band Receiver  
**MVT-7300EU**  
Instruction Manual

**MVT-7300EU**

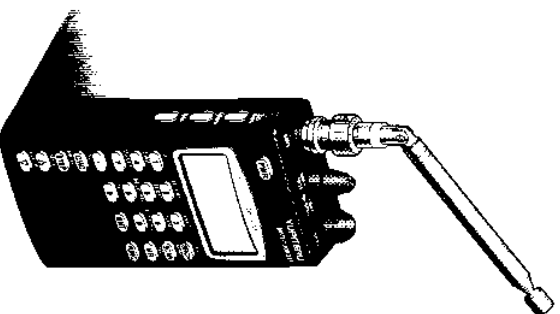

Thank you for selecting our MVT-7300EU Multi-band receiver.

**△IMPORTANT**

Please read the manual from beginning to end to familiarize yourself with the unit before attempting to operate the equipment. The instruction manual is designed to provide the user with a better understanding of the MVT-7300EU. Keep it in a convenient place for future reference.

**YUPITERU INDUSTRIES CO., LTD.**  
12-33, Shibaura 4-chome, Minato-ku, TOKYO  
100-0021 JAPAN  
TEL: 03-30625

# NAMES AND FUNCTIONS

Refer to this page as necessary while you read the instructions.

INTRODUCTION

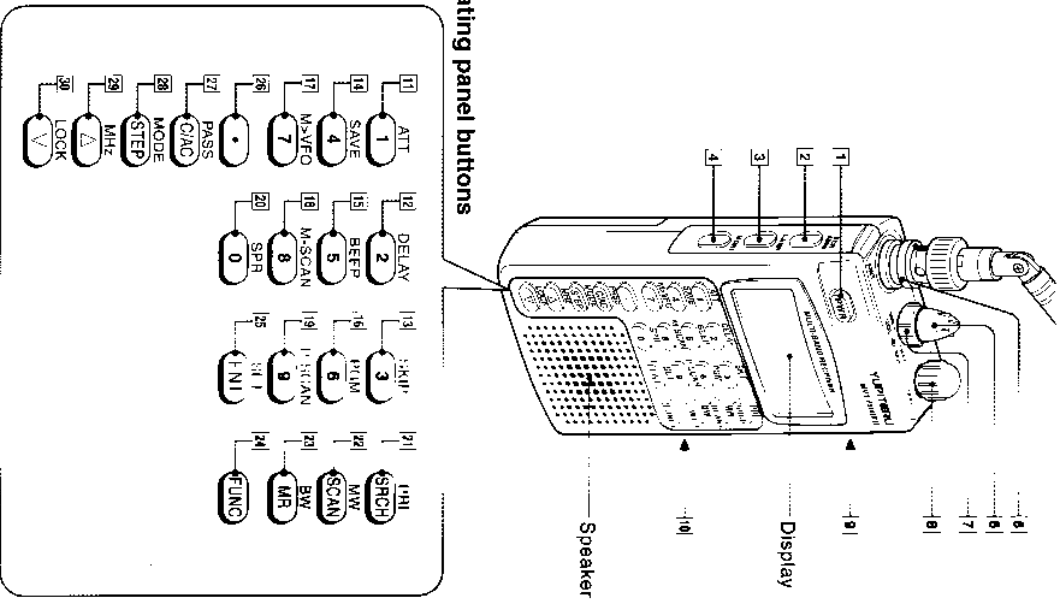

# FEATURES

## Frequencies 531 KHz up to 1,320 MHz in all modes

This receiver can cover a wide frequency range, from 531 KHz to 1,320 MHz modulated in W-FM, FM, AM, N-AM or CW, either LSB or USB.

\* Note that the display can read from 100 KHz to 1,320 MHz.

## High-speed scanning and searching

Scans/searches as many as 30 channels / 30 steps per second.

## Various frequency scanning steps

Frequencies can be scanned upward and downward in steps of 50 Hz and up to 125 KHz, for a total of 16 steps, allowing the best suitable choice for the channel and mode being selected.

\* Frequency steps available depend on the reception mode selected.

## 10-band searching

The unit comes with 10 major bands, including FM and aeronautical communications (AIR BAND) registered. You can modify these registrations.

## 1000-channel memories

You can store up to 1,000 of your favorite channels in the memory. This receiver is also equipped with various channel memory scan functions, bank scan, mode scan, program scan and priority, which increase the efficiency of receiving frequencies. The search pass memory can register up to 500 frequencies that will be excluded from searching.

## Descrambler

The unit contains descrambler circuitry capable of deciphering are restoring scrambled transmissions.

## Timer

During power-off, the display shows times of day. The timer can be set to sound an alarm or to turn power on/off.

## Versatile display with backlight, key illumination

The backlight can be toggled between yellow-green and orange.

## Power supply option

This receiver can be run from alkaline dry cell or nickel cadmium batteries; an ordinary household electrical outlet via AC adaptor, or from car batteries through 12V cigarette-lighter socket.

## Data duplication

Contents of memory can be copied to another MVT-7300EU memory.

# SAFETY PRECAUTIONS

For safe operation of the receiver, you should read and follow all warnings and cautions. In this manual, warnings and cautions identify conditions or practices that could result in personal injury or damage to the equipment or other property.

## ⚠️ WARNINGS:

Warnings indicate danger of personal injury or loss of life if not observed.

## ⚠️ CAUTION:

Cautions indicate the possibility of minor personal injury or property damage if not observed.

### Symbol Key

- ⚠️ ⚠️ Indicate situation requiring special attention.
- ⚠️ ⚠️ Indicate actions that are forbidden.
- ⚠️ ● Indicate required actions or procedures.

## ⚠️ WARNINGS:

- ⚠️ Do not wet the receiver. Do not handle the receiver with wet hands. Failure to observe this warning may result in fire or electrical damage or injury.
- ⚠️ Do not use the receiver while bathing. Do not connect or disconnect the power plug with wet hands. Failure to observe this warning may result in personal injury from electric shock.
- ⚠️ Do not operate the receiver at voltage other than that indicated on the receiver. Failure to observe this warning may result in fire or electrical damage or injury.
- ⚠️ Do not damage, forcibly bend, or modify the power cord. Do not use a damaged power cord. Failure to observe this warning may result in personal injury from electric shock or fire due to short circuit.
- ⚠️ Do not plug the receiver power cord into an outlet where too many devices are connected. Failure to observe this warning may result in equipment damage or fire due to overheating. This receiver is designed for use with a negative grounded car power supply. When connecting to the car power supply, make sure polarity is correct.
- ⓘ When using an AC adaptor or cigarette lighter plug, plug it into the socket securely. A loose connection could result in fire.
- ⓘ Keep the blades of the AC adaptor and the tip of the cigarette lighter plug clean. A dirty contact point may result in fire.
- ⚠️ Do not use an AC adaptor or cigarette lighter plug other than specified ones. Failure to observe this warning may result in fire or electrical damage or injury.

## ⚠️ WARNINGS:













- ⚠️ Do not put a metallic object such as a pin or wire into a hole or slot in the receiver. Failure to observe this warning may result in fire or electrical damage or injury.
- ⚠️ Do not modify the receiver and/or its accessories. Failure to observe this warning may result in fire or electrical damage or injury.
- ⓘ If the housing is damaged, immediately disconnect from the AC adaptor or cigarette lighter plug. Continued operation may result in fire or electrical damage or injury.
- ⓘ Do not use the receiver during an electrical storm. Personal injury from electric shock may result.
- ⓘ Disassembly or repair of the receiver and its accessories should be repaired only by a qualified service engineer. Failure to observe this warning may result in electrical damage or injury. Refer inspection, adjustment or troubleshooting to your local dealer.
- ⚠️ Do not operate the receiver while driving. Not concentrating on driving can result in a serious traffic accident.
- ⓘ When using the receiver in a car, do not install the receiver where it will disturb the driver or hinder access to driving controls (brake, steering wheel, etc.) Poor installation could result in a traffic accident.
- ⚠️ When using the receiver in a car, do not install the receiver or run the wiring near the air bag on the seat next to the driver. The inflating air bag has sufficient energy to throw the receiver and cause severe injury. Also, the power cord of the receiver can interfere with operation of the air bag.
- ⚠️ Do not operate the receiver if it seems defective (emanating smoke or unpleasant odor). Disconnect from the AC adaptor or cigarette lighter plug to prevent fire. Return the receiver to your local dealer for repair.

INTRODUCTION

Continued on next page

## SAFETY PRECAUTIONS

### **CAUTION:**

-  **Do not run the power cord close to heat generating devices.**  
A melted cord cover can result in fire or electric shock.
-  **Do not place the receiver on unstable or vibrating surfaces or places subject to impact.**  
If the receiver falls or is dropped it can cause injury or be damaged.
-  **When disconnecting the receiver from the power source, do not tug on the power cord.**  
To unplug, grip the plug itself and pull. A damaged cord may result in injury from electric shock or fire from a short circuit.
-  **When moving the receiver, first disconnect the AC adaptor or cigarette lighter plug.**  
A damaged cord may result in injury from electric shock or fire from a short circuit.
-  **Install the batteries with the correct polarity.**  
Reversing polarity may cause the battery to explode or leak electrolyte, resulting in fire, injury, or contamination of the surroundings.
-  **Do not use batteries other than those specified. Do not use a combination of new and old batteries.**  
Failure to follow this instruction may result in the explosion of the battery or leakage of electrolyte, which can cause fire, injury, or contamination of the surroundings.
-  **Do not throw used batteries into fire.**  
Failure to follow this instruction may result in injury from burns and/or fire.
-  **Disconnect from the AC adaptor or cigarette lighter plug before carrying out maintenance of the receiver.**  
Failure to follow this instruction may result in injury from electric shock.
-  **Disconnect the AC adaptor or cigarette lighter plug when the receiver is not going to be used for an extended period.**  
Failure to follow this instruction may result in personal injury from electric shock due to deteriorated insulation or fire due to leakage.
-  **Remove the batteries when the receiver is not going to be used for an extended period.**  
Electrolyte leakage may result in contamination.
-  **Be careful not to set the audio level too high when listening through earphones or a headset.**  
Failure to observe this recommendation may result in injury to your ears.
-  **Do not use the receiver in an airplane.**  
RF energy from the receiver may interfere with navigation instruments.
-  **Do not use the receiver in a hospital.**  
Radio frequency energy radiated from the receiver may interfere with electrical medical equipment.

## CONSIDERATIONS ON USING THE RECEIVER

### Handling Considerations

- When cleaning the receiver, use a soft cloth.  
Do not use benzene, thinner, detergent, or a cloth that is prone to build up static, such as polyester.
- Being a wide bandwidth receiver, spurious radiation inside the receiver may mask some incoming transmissions or generate noise. It may also interfere with radio receivers and TV sets operating nearby.
- The receiver may pick up noise from radio or television receivers, PCs and other digital devices, or equipment installed in the car.
- As damage could result, avoid using or storing the receiver in the following places:
  - places exposed to high temperatures (such as in direct sunlight, near heating units, in a hot car, etc.)
  - places exposed to high humidity
  - places with poor ventilation
  - places exposed to excessive dust or greasy fumes
  - extremely cold places

### Memory

- The receiver will store the operating configuration at the time it is turned off by pressing the PWR button 1. Unless the stored data is erased by cutting the external power source or removing the batteries while the unit is on, the next power up will be with the configuration stored when the receiver was previously turned off.

### Antenna

- The sensitivity of the receiver depends on the receiving location and the antenna used.
- A high power transmission from a TV broadcasting station could interfere with the receiver, depending on the location of the receiver and the antenna being used.
- In addition to the unit's telescopic antenna, commercially available antennas for amateur wireless use can be used; when doing so, use an antenna that matches the target frequency. Do not use an antenna with a booster as it can damage the receiver circuitry.
- The ANT terminal is a 50 ohms impedance BNC terminal.

### Transmission Contents

- By law, a third party may listen to, but not pass on, the contents of a transmission.

### Timer

- The internal clock may slow or fast by 3 minutes/month maximum. Set the clock as necessary.

- **Encoded Transmissions**  
The receiver cannot decode some encrypted information (e.g. digital data).

# NAMES AND FUNCTIONS

(Continued on next page)

## Controls

- 1 PWR button (power)  
Turns on/off power.
- 2 SCR/AMW button (scramble)  
Restores scrambled transmission. Acts as a memory autowrite key while in the function mode.
- 3 LAMP button (illumination)  
Illuminates the display and keyboard. Press this button when you cannot see the display or keyboard.
- 4 MONI button (monitor)  
Improves reception for weak or intermittent transmissions.
- 5 ANT socket (antenna socket)  
Socket for the attachment of an antenna.
- 6 VOL knob (volume control)  
Turning this knob clockwise increases the sound level.
- 7 SQL knob (squelch)  
Mutes static when there is no signal. When properly adjusted, provides noiseless tuning.
- 8 DIAL knob (tuning)  
Switches between frequency or channel memory. Adjusts desatrating level on a signal currently being received.
- 9 EAR terminal (external speaker)  
For attachment of an external speaker or earphones. This socket, once engaged, disables the internal speaker.
- 10 12VDC socket (external power socket)  
For attachment of the AC adaptor or cigarette lighter plug.

## Keypad

Each key performs additional function if used in conjunction with the FUNC key [24].  
When a key is pressed without the FUNC key being pressed, the function shown on the key is activated as illustrated below.

### Extended function in the direct input mode

Key	Function
1	Numerical key (1)
2	Numerical key (2)
3	Numerical key (3)
4	Numerical key (4)
5	Numerical key (5)
6	Numerical key (6)
7	Numerical key (7)
8	Numerical key (8)
9	Numerical key (9)
0	Numerical key (0)
SEARCH	Search key
SCAN	Scan key
MEM	Memory read key
FUNC	Function key
ENT	Enter key
.	Decimal point key (.)
CLR	Clear/all clear key
STEP	Step key
UP	Up key
DOWN	Down key

PRI  
SRCH — Extended function in the direct input mode

- 24 FUNC key (function)  
Use this key to activate the extended function of a double-function key.

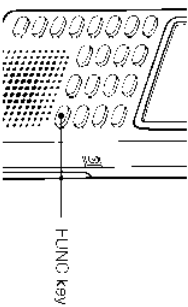

### Extended function in the function mode

Press the FUNC key [24]. The designation [FUNC] will light. Press a key above the key will be activated.



PRI  
SRCH — Extended function in the function mode

Key	Function
24 → 11	Attenuator key
24 → 12	Delay key
24 → 13	Skip key
24 → 14	Save key
24 → 15	Ramp key
24 → 16	Program key
24 → 17	Memory to VFO key
24 → 18	Mode Scan key
24 → 19	Program Scan key
24 → 20	Search Pass Road key
24 → 21	Priority key
24 → 22	Memory Write key
24 → 23	Band Write key
24 → 25	Set Mode key
24 → 27	Pass key
24 → 28	Mode key
24 → 29	MHz key
24 → 30	Lock key
24 → 2	Memory Autowrite key

## INTRODUCTION

## NAMES AND FUNCTIONS

### Display

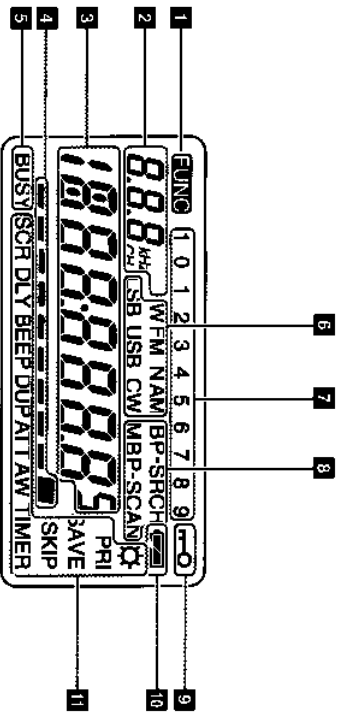

### Frequency readings

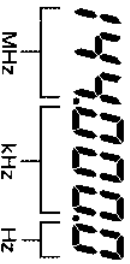

### Blinking & flashing

At slow or fast rate depending on setting.

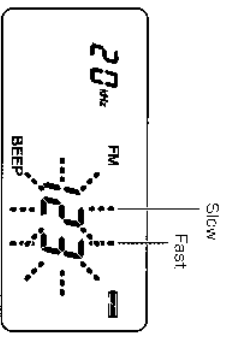

INTRODUCTION

**1** Function  
[EUNO] is displayed while in function mode.

**2** Frequency step/channel memory display  
Indicates the frequency step [kHz] while in search or VFO mode.  
Indicates the channel number [CH] while searching, scanning or memory reading.  
[P CH] indicates the priority channel.

**3** Frequency display  
Indicates the selected frequency or digits being input. When shipped from the factory, the frequency display reads "0.00" when power is first connected. Once the internal clock is set, this display indicates the current time while the unit is off.

**4** Signal strength (S meter)  
Displays signal strength.

**5** BUSY  
Turns on to indicate that the MONITOR button is being pressed, signal is being received or squelch is being engaged.

**6** Reception mode  
Indicates current reception mode (type of transmission).

**7** Band/Bank number  
Indicates the selected band or bank number.

**8** Operation mode  
Indicates the current operation mode (search, scan, etc.).

**9** Lock  
[LO] is displayed when locked.

**10** Battery symbol  
Indicates the battery capacity.

**The symbol functions as a battery level mark**  
Indicates remaining battery capacity as follows:

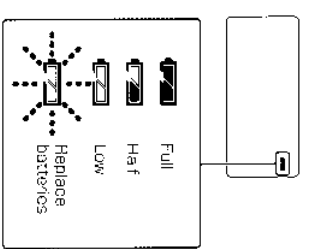

• Display shows nothing when the batteries completely discharge.

**11** Setting  
Displays the current setting.

INTRODUCTION

# ACCESSORIES

## Included Accessories

Check that the following accessories came with the MVT-7300EU.

- Telescopic antenna ..... (1)
- Belt clip ..... (1)
- Earphones ..... (1)
- Instruction manual ..... (1)

## Attaching the Antenna

Align the slot in the antenna with the projection on the ANT socket, slip the antenna onto the socket and gently turn clockwise until it clicks into place.

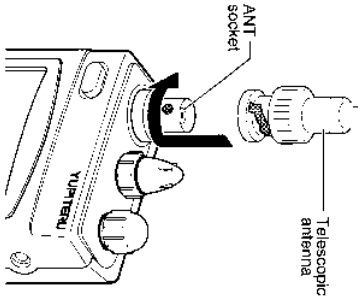

## Attaching the Belt Clip

Remove the belt clip cover and attach the clip.

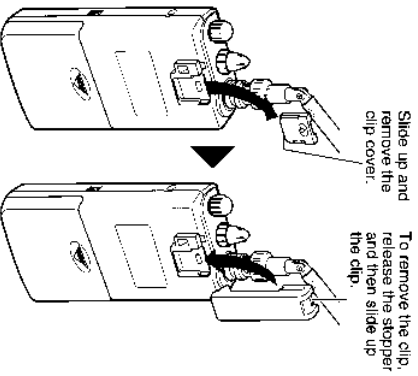

## Attaching the Hand Strap

Attach a commercially available hand strap as shown in the figure below.

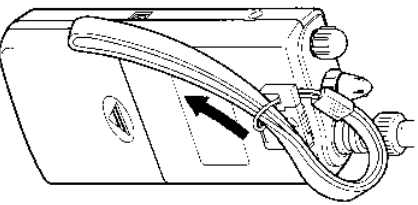

# POWER SUPPLY

The receiver can be operated with an external power source (in the home or car) via AC adaptor or cigarette lighter plug, or with an alkaline or nickel cadmium battery.

\*When shipped from the factory, reads "0:00" when power is first connected with the power switch off. For setting the internal clock, refer to the section, "Setting the time of day".

## Using an External Power Supply

**1** Connect the AC adaptor or cigarette lighter plug to the 12VDC socket 10.

Always turn off the power before attaching the AC adaptor or cigarette lighter plug.

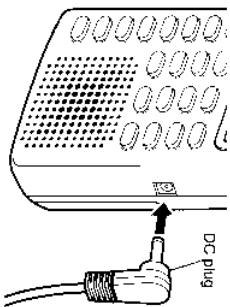

**2** Plug the AC adaptor into an AC outlet; or plug the cigarette lighter plug into the cigarette lighter socket (12VDC).

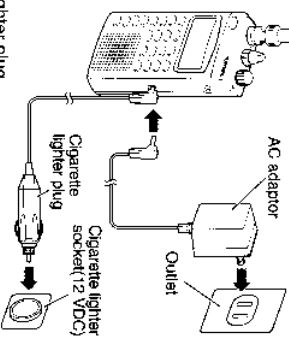

- Use only the specified AC adaptor or cigarette lighter plug.
- The cigarette lighter plug is designed to connect to a 12VDC car power supply whose negative terminal is grounded. Do not connect the plug to a socket supplying 24VDC (used in large vehicles such as busses and heavy trucks).
- If the 1A fuse inside the cigarette lighter plug is blown, replace it with a new 1A fuse. If the fuse blows immediately, discontinue use, disconnect the cigarette lighter plug, and consult your local dealer or service center.
- When removing the blown fuse, take care not to miss the spring contained in the cigarette lighter plug. Insert the new fuse and spring as before.

## Using Alkaline or Nickel Cadmium Batteries

**1** Remove the battery compartment lid. Always turn off the receiver before changing the batteries.



**2** Install 3 batteries as indicated in the battery compartment. Close the lid.

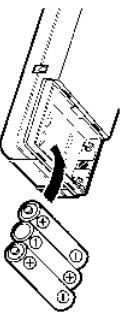

- When using nickel cadmium batteries, use fully charged ones since the unit has no recharging circuit.
- When rechargeable batteries are discharged, remove them from the receiver and recharge from an external power supply since the unit has no recharging circuit.
- Do not use batteries of different types at the same time. Do not use a combination of new and old batteries.
- Remove the batteries when the receiver is not going to be used for an extended period.

## PREPARATION

### 1 Turn on power.

Press and hold the PWR button [1].



• When turned on initially, the receiver display appears as shown below.



### 2 Turn the SQL knob [7] counter-clockwise all the way.

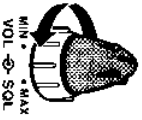

• Turning the SQL knob [7] clockwise too far makes reception of weak signals difficult, and turning it too far counter-clockwise increases static. Adjust as required for the signal you wish to receive.

### 3 Adjust the volume.

Adjust the VOL knob [6] for the desired audio level.



### 4 Adjust reception (squench).

When there is static, turn the SQL knob clockwise until the static is muted. While adjusting, do not press the MONI button [4] (see Monitor, page 40).

The SQL knob should be set about midway while receiving a transmission.



## RECEIVING IN VFO MODE

*Continued on next page*

### VFO Mode

In VFO mode, frequencies can be entered or changed with the numeric keys,  $\Delta$  key,  $\nabla$  key, or DIAL knob.

In this mode, [PRI] and the operation mode [SRCH] or [SCAN] are not displayed; neither are channel number and (P). Frequency step shows up in the frequency step/channel memory display.

When you turn on the unit for the first time, you will be in VFO mode.

### Entering VFO Mode

VFO mode can be selected in any of the following four ways.

■ While [SRCH] is displayed, press the SRCH key [2].



■ While [SCAN] is displayed, press the MR key [23] twice.



■ While channel number is displayed, press the MR key [23].

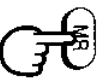

■ While [P] is displayed, press the FUNC key [24] then the SRCH key [2].

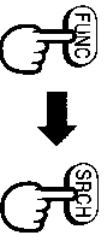

### Reception mode and frequency step

The type of radio wave and frequency intervals between adjacent stations are determined and assigned to a radio station according to its purpose and the frequency band.

To correctly receive the signal from a particular station, set the receiver to the mode compatible with the type of the radio wave and then frequency.

• A radio station may use two or more frequencies. The interval between frequencies may vary depending on the frequency band. Before receiving signals from the desired radio station, select the correct frequency step.



## RECEIVING IN VFO MODE

### Tuning Using Numeric Keys

In VFO mode, you can enter frequencies with the numeric keys.

#### 1 Enter the desired frequency starting with the highest digit:

In other words, MHz, [ ] KHz, then Hz. The value being entered blinks.

#### 2 Press the ENT key [25].

The entered value stops blinking.

- The receiver can receive 100 kHz to 1,320 MHz. If the entered frequency is outside the range of the receiver, a beeping sound is generated and [Error] is displayed for about a second, then the display returns to the previous screen.
- Up to 4 digits can be entered in the MHz display. If the 5th digit is entered without first pressing the decimal point key (.) [26], the entire input becomes invalid. You can enter up to 5 digits in the kHz and Hz displays. Pressing a 6th numeric key following the decimal point causes an error, indicated with a beeping sound, and the entry is ignored.
- To enter a frequency lower than 1 MHz, first press the (.) [26] key and then the numeric keys representing the frequency.
- When entering the frequency, if a key is not pressed for 10 seconds the display returns to the previous screen.

#### Examples of frequency setting

① For the input: (3) (4) (5) (ENT)

Key pressed	Display
3	---
4	---3.4-
5	---34.5-
ENT	345.000.0

(3/5MHz-2)

② If the following keys are pressed:  
(1) (9) (0) (ENT) (frequency outside the receiving range)

Key pressed	Display
?	---
1	---2.1-
0	---21.0-
0	---210.0-
ENT	Err or

(Alarm beeps and the entry is ignored.)

③ When the following keys are pressed:

(1) (1) (2) (3) (4) (5) (6) (7)

(8) (9) (B) (ENT)

Key pressed	Display
1	---
1	---1.1-
2	---11.2-
3	---112.3-
4	---123.4-
5	1234
5	1234.5
6	1234.56-
7	1234.567-
8	1234.567.8-
9	1234.567.85

(The '1' (first entered) is cancelled.)

(If a key pressed at the 5th decimal place is 5 or higher number, it is recognized as 5, otherwise, '9' (no record).)

Continued on next page

#### Changing or Correcting a Frequency Being Entered

When entering a frequency, any digit in the string can be selected and changed.

#### 1 Press the C/A/C key [27].

The digit entered last will blink at a faster rate.

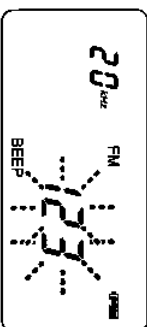

• Press the C/A/C key [27] again to return to VFO mode.

#### 2 Select the desired digit by using the Δ key [28] or ▽ key [30].

The digit blinking at a faster rate can be changed.

#### 3 Input the correct value.

Use the DIAL knob [8] or the numeric keys.

#### 4 Press the ENT key [25].

Returns to input mode.

If there are more digits, the next digit may be entered.

• If a key is not pressed within 10 seconds, the display returns to the previous screen.

#### 5 Press the ENT key [25] again.

The input value is entered.

## RECEIVING IN VFO MODE

### Tuning with the DIAL Knob

In VFO mode, turning the DIAL knob [8] increments or decrements the current frequency one designated frequency step at a time.

#### To increase frequency

Turn the DIAL knob [8] clockwise.



#### To decrease frequency

Turn the DIAL knob [8] counterclockwise.



### Tuning with the ▲ and ▼ keys

In VFO mode, pressing the ▲ key [29] or ▼ key [30] respectively increments or decrements the frequency one designated frequency step.

#### To increase frequency

Press the ▲ key [29].



#### To decrease frequency

Press the ▼ key [30].



Pressing and holding the ▲ key [29] or ▼ key [30] for more than a second increments or decrements frequency at a faster rate.

### Changing Frequency in MHz Units

Follow the procedure shown below:

#### 1 Press the FUNC key [24].

[FUNC] will light.



#### 2 Press ▲ key [29].

The number at the 1 MHz place (e.g. 4 in the figure below) blinks faster.



#### 3 Press ▲ key [29] or ▼ key [30] to select the digit place you want to change.

The value so that it starts blinking faster.

#### 4 Enter the correct number via DIAL knob [8] or the numeric key.

#### 5 Press ENT key [25] to accept the new value.

• To cancel the input, press C/AC key [27]. The display returns to the original readings.

## RECEIVING IN SEARCH MODE

(Continued on next page)

In VFO mode, a search starts at the displayed frequency.

### VFO Search <Continuous Search>

This is a function to search a frequency and receive it automatically.

Searching is done in the selected receive mode and frequency steps. If the reception is interrupted for 2 seconds or more, searching continues.

• The time delay from interruption to restart can be extended to approx. 4 seconds. See "Changing Delay Time" on page 38.

### VFO Searching

Press the SRCH key [21].

[SRCH] is displayed, indicating the start of the search.

Searching

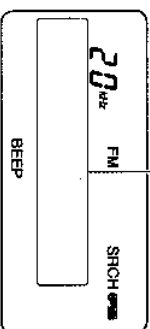

Press the SRCH key [21] again to abort search. [SRCH] will no longer be displayed.

#### Resuming search

• Operating the DIAL knob [8], ▲ key [29] or ▼ key [30] while search is suspended (i.e. while receiving) resumes searching.

### Changing Search Direction

Use the DIAL knob [8], ▲ key [29] or ▼ key [30].

#### Higher frequencies search

Turn the DIAL knob [8] clockwise, or press the ▲ key [29].

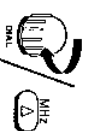

#### Lower frequencies search

Turn the DIAL knob [8] counterclockwise, or press the ▼ key [30].

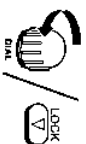

## RECEIVING IN SEARCH MODE

### What is the Band Search?

Even when the frequency of a station is unknown, if its operating band is known, you can search the entire band for it. Up to 10 user-reprogrammable search bands can be stored in the unit.

#### Band Preset List

BAND	FREQUENCY(MHZ)	STEP(KHZ)	MODE
1	88,000 - 107,950	50	WFM
2	108,000 - 137,000	25	AM
3	144,000 - 145,975	25	FM
4	146,000 - 154,000	12.5	FM
5	156,000 - 162,500	25	FM
6	175,750 - 221,750	25	FM
7	430,000 - 440,000	25	FM
8	450,000 - 460,000	25	FM
9	850,000 - 859,000	12.5	FM
0	903,750 - 904,000	12.5	FM

### Searching Bands

#### 1 Using numeric keys, enter the band number (band selection).

#### 2 Press the SRCH key [2].

<Example: band 3 selected>

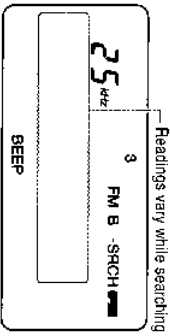

The blinking band number indicates the search has been suspended.  
To exit band search mode, press the SRCH key [2]. [B-SRCH] will no longer be displayed.

## SEARCH PASS MEMORY

(Continued on next page)

By designating unwanted frequencies as search pass, more efficient searching is possible because the designated frequencies are bypassed.

### Designating Frequencies as Search Pass

#### 1 Turn to an unwanted frequency.

Use VFO or search mode.



#### 2 Press the FUNC key [2].

[FUNC] will light.

#### 3 Press the C/AC key [2].

Beep tones sound and [P] appears for several seconds, which indicate that the frequency being received is now registered and will not be received again. The searching continues.



• Up to 500 frequencies can be entered. Once full, trying to make another entry generates a beeping sound and [FULL] is displayed for about a second; the entry is ignored.

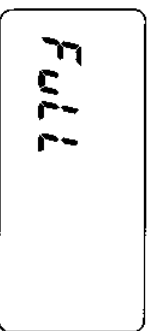

### Accessing Search Pass Memory

Designated search pass frequencies can be retrieved and verified.

#### 1 Press the FUNC key [2].

[FUNC] will light.

#### 2 Press numeric key 0 [0].

[P] starts blinking and the receiver begins searching for a frequency higher than the one currently being received. If this operation is started while in the search mode, the next search pass frequency in the searching direction is called.



• If no search pass frequencies have been designated, a beeping sound is generated and [Error] is displayed for about a second.

#### 3 Selecting a Frequency from Search Pass Memory.

Use the DIAL knob [8],  $\Delta$  key [26] or  $\nabla$  key [26].  
For a faster search, press and hold the  $\Delta$  key or  $\nabla$  key for more than 1 second.

To cancel the search pass memory reading, press C/AC [2] key (or repeat steps 1 and 2). The receiver enters VFO mode, starting with the frequency being called.

## SEARCH PASS MEMORY

### Cancelling Search Pass Designations

Frequencies can be removed from search pass memory.

- 1 Retrieve the frequency to be removed.**  
Retrieve as per accessing Search Pass Memory.
  - 2 Press the FUNC key [24].**  
[CANCEL] will light.
  - 3 Press the C/AC key [27].**  
Two beeps indicates that the frequency is no longer designated search pass.
- Once an entry is deleted, the next higher search pass frequency is displayed.
  - If the number of search pass entries is great, deletion of the entries requires several seconds.
  - When all of the search pass entries are deleted, a beep sounds and you return to the VFO mode and to the frequency recovered last.

## CHANNEL MEMORY

(Continued on next page)



The channel frequencies to which you often listen can be stored in channel memory. The stored channels can be retrieved (scanned) automatically. Refer to "SCANNING" (page 29).

### Data that can be entered

The following data can be entered for each channel.

- Frequency
- Frequency step
- Reception mode
- Attenuator on/off (page 42)
- Scan pass registration setting/cancelling (page 27)

### Storing a Frequency in Channel Memory

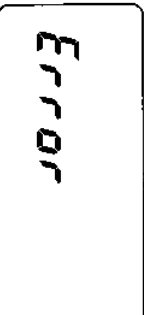
- 1 Find the frequency to be stored.**  
Use VFO or search mode.
  - 2 Input the channel number.**  
Enter a channel number (from 0 to 1000) for the frequency with the numeric keys.
  - 3 Press the FUNC key [24].**  
[FUNC] will light.
  - 4 Press the SCAN key [21].**  
Two beeps are generated and the channel number is displayed for about a second.
- 
- 
- 
- Channel number 1000 is assigned to the priority channel (page 34).
  - The frequency can also be stored without entering a channel number. In this case, the next available channel number higher than the most recently displayed channel number is assigned automatically.
  - Reassigning a channel number will overwrite the previously registered channel number. If the existing entry to be overwritten has related scan pass or program scan registration (page 27, page 32), the registration is removed from that channel.
  - The display returns to the one as shown in step 1 above.
  - If an invalid channel number is entered, a beeping sound is generated and [Error] is displayed for about a second.

## CHANNEL MEMORY

(Continued on next page)

### Accessing Channel Memory

Channels can be retrieved from channel memory.

#### 1 Enter the channel number to be retrieved.

Use the numeric keys to enter the channel number (0-1000). Entering 1000 calls the priority channel (page 34).

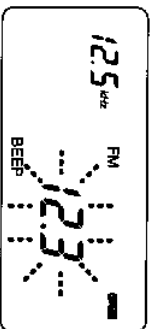

#### 2 Press the MR key [23].

The channel is retrieved from channel memory.



- If there is no data for the channel number selected, the frequency 000.000.0 is displayed, but the receiver continues to receive the frequency to which it was tuned before the operation.

- If the MR key [23] is pressed without first specifying a channel number, the most recently retrieved channel is retrieved again.

- Entering an invalid channel number results in an error; a beeping sound is generated and [Error] is displayed for about a second.

#### 3 Retrieving another channel from memory.

Use the DIAL knob [8],  $\Delta$  key [29] or  $\nabla$  key [30].

Pressing and holding the  $\Delta$  key or  $\nabla$  key for more than 1 second allows fast scanning.

To abort, press the MR key [23] to return to VFO mode.

### Deleting an Entry from Channel Memory

#### 1 Retrieve the channel to be deleted.

Retrieve as per Accessing Channel Memory.

#### 2 Press the FUNC key [21].

[FUNC] will light.

#### 3 Press the SCAN key [22].

Two short beeps indicate the entry is deleted from channel memory and 000.000.0 is displayed as the frequency (although reception continues).



- The priority channel cannot be deleted (page 34).

### Copying a Frequency in Channel Memory to VFO Mode

A frequency stored in the channel memory can be used in the VFO mode.

#### 1 Retrieve the channel to be used.

Use the channel memory read or scanning process.

#### 2 Press the FUNC key [21].

[FUNC] will light.

#### 3 Press numeric 7 key [17].

The channel memory frequency is copied and the receiver enters the VFO mode.

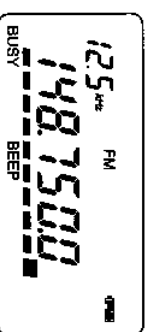

- In addition to the frequency, the associated frequency step, receive mode, attenuator, function setting, etc., registered in the channel memory are also copied.
- The priority channel cannot be copied.

### Designating Channels as Scan Pass

By designating certain channels in channel memory as scan pass, then can be skipped when scanning.

#### 1 Retrieve the channel to be skipped.

Retrieve as per Channel Memory Retrieval or by scanning. (You can designate a channel when receiving it.)

#### 2 Press the FUNC key [21].

[FUNC] will light.

#### 3 Press the C/AC key [27].

Two short beeps indicate the channel has been designated scan pass; [CH] starts to blink. Subsequent scanning will bypass the channel.

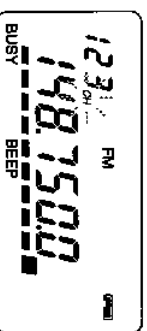

- A channel that has been designated scan pass can be retrieved by Channel Memory Retrieval. This causes [CH] to blink.
- Priority channels cannot be designated scan pass.
- Designating a channel that is being received as scan pass causes scanning to commence. If all channels are designated as scan pass, a beeping sound is generated and [ALL PASS] is displayed for about a second.



## CHANNEL MEMORY

### Scan Pass Designation Cancellation

A scan pass designation can be cancelled.

- 1 Retrieve the channel.**  
Retrieved by Accessing Channel Memory.

- 2 Press the FUNC key [24].**  
[FUNC] will light.

- 3 Press the C/AC key [27].**  
The channel is no longer designated scan pass.



• [CH] stops blinking.

## SCANNING (channel memory scanning)

(Continued on next page)

The scanning function retrieves channels from channel memory and uses them in turn to search for stations.

### About Scanning

The MVT-7300EU is capable of two types of scanning: sequential and bank scanning. The scanning function retrieves channels sequentially from channel memory and uses them in turn to automatically search stations in these channels.

Each scan can be performed either in the mode in which the stations that match the selected receive mode are received, or in the programmed scanning mode in which stations in the registered channels are received. The unit can register up to 1,000 channels in 10 banks, 100 channels per bank.

Channel No.	Bank	Bank Selection Key
000~099	1	(1)
100~199	2	(2)
200~299	3	(3)
300~399	4	(4)
400~499	5	(5)
500~599	6	(6)
600~699	7	(7)
700~799	8	(8)
800~899	9	(9)
900~999	0	(0)

• Channels 950-999 of Bank 0 also serves as the auto write bank (See 'Auto Write', page 36).

### Sequential Scanning <All Channels>

The MVT-7300EU scans channels in channel memory in the order of channel number and locks onto the signal of the first station it locates.

Press the SCAN key [22].

[SCAN] and the numbers of banks that can be scanned are displayed, indicating the start of scanning. When the scanning is suspended, the number of the channel being received is displayed and the bank number of that channel blinks.

Scanning: display changes

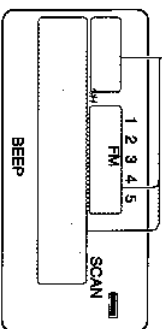

<Example where banks 1-5 have channel memory registrations>

To abort, press the SCAN key [22] or MR key [20]. [SCAN] and bank No. are turned off and the mode changes to channel memory reading.

- Pressing the SCAN key [22] while in channel memory reading, program scanning or mode scanning, starts scanning the channel whose channel number is higher by 1 than that being called.
- If the receiver fails to hold the current station for more than 2 seconds, it resumes scanning to find the next station. The 2-second waiting time can be extended to 4 seconds. See time delay selection on page 36.
- Pressing the SCAN key [22] with nothing stored in the channel memory, [Error] is displayed for 1 second and a beep sounds. The receiver returns to the state before the operation.
- If all of the channels are designated scan pass, a beeping sound is heard and [ALL PASS] is displayed for about 1 second. The receiver returns to the state before the operation.

## SCANNING (channel memory scanning)

### Selecting Scanning Direction

Use the DIAL knob [8],  $\Delta$  key [29] or  $\nabla$  key [30].

#### Scanning Channels in Increasing Order

Turn the DIAL knob [8] clockwise, or press the  $\Delta$  key [29].

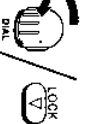
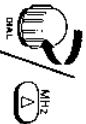

#### Scanning Channels in Decreasing Order

Turn the DIAL knob [8] counter-clockwise, or press the  $\nabla$  key [30].

• Using the DIAL knob [8],  $\Delta$  key [29] or  $\nabla$  key [30] while receiving a station causes scanning to commence.

### 2 Press the SCAN key [2].

[B-SCAN] and the number of the bank that can be scanned are displayed and the scanning starts.

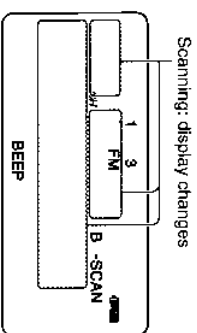

<Example: banks 1 and 3 are specified and scanned>

When the scanning is suspended, the number of channel being received is displayed and the associated bank number blinks.

To stop scanning, press the SCAN key [2] or MF key [23]. [B-SCAN] ceases to be displayed and the receiver returns to channel memory retrieval mode.

- The receiver scans registered channels starting in the order of channel number regardless of the order of banks specified.
- If none of the channels in the specified bank are registered, a beeping sound is generated and [Error] is displayed for about 1 second and the receiver will return to the preceding mode.
- If all of the channels in the specified bank have been designated scan pass, a beeping sound is generated and [ALL PASS] is displayed for about a second and the receiver will return to the preceding mode.

## RECEIVE MODE SCANNING

The sequential scanning or bank scanning can be performed in the selected receive mode.

### Sequential Scanning in the Mode Scan Mode

In the VFO mode, select the receive mode. (See page 36.)

#### 1 Press the FUNC key [24].

[FUNC] will light.

#### 2 Press the numeric key 8 [8].

[M-SCAN] and the number of bank of channels that can be scanned are displayed and the scanning starts. The selected receive mode blinks.

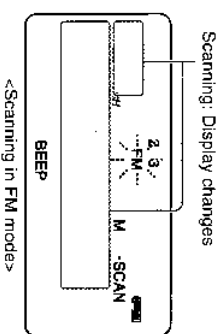

When the scanning is suspended, the number of channel being received lights and the bank number of that channel blinks.

To cancel receive mode scanning, repeat the steps 1 and 2 above. The unit returns to channel memory reading mode in the channel being received or scanned.

- If there is no channel registered in the receive mode for the corresponding memory channel, a beeping sound is generated and [Error] will be displayed for 1 second and the receiver will return to the preceding mode.
- If all the relevant channels are registered for scan pass memory, a beeping sound is generated and [ALL PASS] will be displayed for 1 second and the receiver will return to the preceding mode.

### Bank Scanning in the Mode Scan Mode

In the VFO mode, select the reception mode. (See page 36.)

#### 1 Select the bank(s) (up to 4 banks) to be scanned by pressing the corresponding numeric key(s).

#### 2 Press the FUNC key [24].

[FUNC] will light.

#### 3 Press the numeric key 8 [8].

The scanning starts for the specified bank(s).

# PROGRAMMED SCANNING

Function for scanning only programmed and registered channels. Up to 100 channels (from 10 banks holding 10 channels each) can be scanned.

## Selecting the Channels to Be Programmed (Registering Program Scan)

### 1 Select the desired channel memory read function.

(Registration can be performed while scan receiving.)

### 2 Press the FUNC key [24].

[FUNC] will light.

### 3 Press the numeric key 6 [16].

Two beeps sound to indicate registration of programmed scan. [P] will appear above the frequency window for 1 second and then blink. The display also shows, for 1 second, how many channels are programmed and registered in the bank to which the memory belongs.

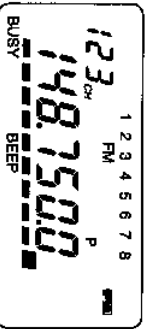

To cancel the program registered, select it through program scanning and perform steps 2 and 3 (when all registered programs are deleted or all the programs for the specified bank are deleted, a beep is sounded and the receiver enters memory read status in the channel deleted last).

- If an attempt is made to register a frequency, etc., into a channel which has been programmed and stored in memory, it is deleted from program scan channel memory.
- When a program scan registered channels called through the memory read or scanning, [P] flashes above the frequency display.

- Up to 10 channels in a bank can be programmed and registered. The 11th channel will delete the channel registered first; 12th channel will delete the channel registered second; and so on.
- The channel memory holding scan pass can be designated as a program registration channel.
- Priority channel cannot be specified as a program registration channel.

## Programmed Scanning

### 1 Press the FUNC key [24].

[FUNC] will light.

### 2 Press numeric key 9 [19].

[P-SCAN] and the No. of bank containing channels programmed to be scanned are displayed and the scanning starts.

When the scanning is suspended, the channel number being received lights and the number of the bank corresponding to the channel number blinks.

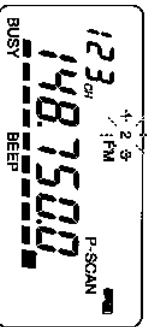

To cancel, repeat steps 1 and 2. Channel memory reading starts in the channel being received or scanned.

- If programmed scanning is attempted with no program registered, beep sounds and [ERROR] is displayed and the receiver returns to the state as before the step 1.

## Programmed Bank Scanning (Bank Specified)

### 1 Using the correct numeric key, select the bank to be scanned.

Up to 4 banks can be selected.

### 2 Press the FUNC key [24].

[FUNC] will light.

### 3 Press numeric key 9 [19].

The scanning starts.



## PRIORITY

While receiving in VFO, search, scan, or channel memory access modes, priority channel is scanned sequentially in 5 second intervals.

### Priority Channel Designation

The priority channel is stored in the memory as channel 1000.

- 1 Receive the frequency to be registered.
- 2 Input the channel number.  
Using the numeric keys 1 and 0, enter 1000.
- 3 Press the FUNC key [24].  
[FUNC] will light.



Now the registration is completed and the display returns to the previous state as in step 1.

- At the factory, 350.1 MHz (FM) is registered in the priority channel.

### Scanning Priority Channels

- 1 Press the FUNC key [24].  
[FUNC] will light.
- 2 Press the SRCH key [21].  
[PRI] is displayed indicating the start of priority channel scanning.

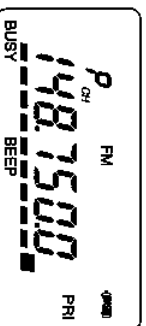

<Priority channel received: VFO mode>

- In this mode, the receiver watches priority channel every 5 seconds and receives this frequency at the highest priority. When the signal is interrupted, the receiver goes back to the normal receiving mode.

To cancel the priority channel scanning, repeat steps 1 and 2.

## CHANGING FREQUENCY STEP AND RECEPTION MODE

*Continued on next page*

### Changing Frequency Step

The frequency step can be changed while in VFO or search mode.

- 1 Press the STEP key [28].  
The current frequency step (value and unit) blink.



- 3 Press the ENT key [25].  
The frequency step is displayed and is changed to the one selected.



<Frequency step is changed to 10 kHz>

- 2 Select the new frequency step.  
Use the DIAL knob [8] or arrow keys [29] and [30].  
Note that the width of the frequency step depends on the reception mode.

Reception Mode	Selectable Frequency Step
FM, AM	1kHz, 5kHz, 6.25kHz, 8.33kHz, 9kHz, 10kHz, 12.5kHz, 15kHz, 20kHz, 25kHz, 30kHz, 50kHz, 100kHz
NAM	100kHz
W-FM	25kHz, 50kHz, 100kHz, 12.5kHz
CW, LSB	50Hz, 100Hz, 1kHz, 5kHz, 6.25kHz, 8.33kHz, 9kHz, 10kHz, 12.5kHz, 15kHz, 20kHz, 25kHz, 30kHz, 50kHz, 100kHz
USB	50Hz, 100Hz, 1kHz, 5kHz, 6.25kHz, 8.33kHz, 9kHz, 10kHz, 12.5kHz, 15kHz, 20kHz, 25kHz, 30kHz, 50kHz, 100kHz

To abort the operation, press the C/CA key [27] or STEP key [28] again.

Go to the step 3 within 10 seconds, otherwise, the receiver will return back to the state as before step 1. The receiver also will return back to the state before step 1 once it is turned off and on again.

### OTHER FUNCTIONS

- If the frequency displayed is not a multiple of selected frequency step, the frequency is changed to an integral multiple of the step.
- Changing the frequency step during band search operation also changes memory contents for search band (p.22). Then, band searching will be performed with new frequency steps.

## CHANGING FREQUENCY STEP AND RECEPTION MODE

### Changing Reception Mode

The reception mode can be changed while in VFO or search mode.

- 1 Press the FUNC key [24].  
[FUNC] is displayed.

- 2 Press the STEP key [26].  
The current reception mode and frequency step blink.



- 3 Select the new reception mode.  
Use the DIAL knob [8] or arrow keys [29] and [30].

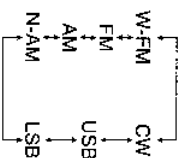

• When new reception mode is selected, the frequency step assigned to that new mode is also selected.

To abort the selection, press the C/CA key [27].

To continue the selection, go to step 4 within 10 seconds, otherwise, the receiver returns back to the state as before step 1.

- 4 Press the ENT key [25].  
The new reception mode is displayed.



• When the reception mode is changed during bands searching, the contents of the search band memory is also changed (see page 22). Subsequent band search will be performed in the new reception mode.

## REPRODUCING SCRAMBLED SIGNALS

In low-power personal radio communications, signals are often scrambled before being transmitted to protect against eavesdropping. Such signals are just noise unless correctly descrambled. The MYT-7300EU is provided with a descrambler for recovering original contents. Note that the descrambler is enabled only in the FM mode.

- 1 While receiving a scrambled signal, press the SCR button [2].  
[SCR] lights up and reproduced voice will be heard.



- 2 Fine tune with the DIAL knob [8] as necessary for easier listening.

- The MYT-7300EU cannot restore any signal encrypted in a way other than scramble.
- Descrambled voice may not be precisely reproduced in terms of sound characteristics.
- Do not press the SCR button [2] except when receiving scrambled transmission.

To disable the descrambler, press the SCR button [2].

While [SCR] is displayed, the DIAL knob [8] cannot change frequency.

OTHER FUNCTIONS

## OPTIONAL FUNCTIONS FOR SEARCHING AND SCANNING

### Changing Delay Time

It takes 2 seconds for the receiver to resume scanning or searching signals after the signal being received was interrupted. With the delay function, this factory set time can be delayed to 4 seconds.

- 1 Press the **FUNC** key [24].  
[FUNC] will light.
- 2 Press numeric key 2 [12].  
[DLY] will light indicating 4-second delay function is activated.



To cancel the delay function, repeat the steps 1 and 2. [DLY] will disappear.

### Skip Function

You can set the receiver to resume searching or scanning in approx. five seconds after the searching or scanning is halted, even during receiving a signal.

- 1 Press the **FUNC** key [24].  
[FUNC] will light.
- 2 Press numeric key 3 [13].  
[SKIP] is displayed. Starting a search or scan activates the skipping function.



To cancel the skip function, repeat the steps 1 and 2. [SKIP] will disappear.

- This function won't work while a priority channel is being received.

### Auto Write

Frequencies found during VFO search operation can be stored in channel memory automatically. Up to 50 channels can be stored in Bank 0 (channel numbers 950 to 999) of the channel memory.

- 1 Enter VFO mode by referring to page 17, "Entering VFO Mode."
- 2 Press the **FUNC** key [24].  
[FUNC] will light.
- 3 Press the **SCR** button [2].  
[AW] will light.
- 4 Perform VFO search (page 21) or band search (page 22).

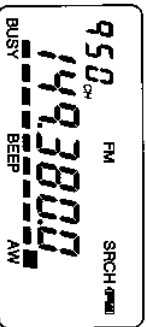

- Search starts and a beep is heard when a signal is received and its frequency is registered.
- The number of channel stored in memory is displayed for 1 second. The search continues.
- The auto write function stores frequencies in memory, starting with channel No. 950 up to 999. When all 50 channels are stored, two beeps are generated and the searching sequence ends and the receiver enters VFO mode.
- Auto write is disabled when its sequence is disturbed by another operation such as repetition of step 1 or 2 or selection of scanning mode.
- If auto write is continued, it restarts with the channel next to the channel already registered. If auto write continues while calling channels 950 to 999 by scanning or channel memory reading, the channel following the channel called last is used.
- It is important to note that the auto write function can overwrite channels 950 to 999.

## CHANGING DATA IN SEARCH BAND MEMORY

### Search Band Memory

While in VFO mode (page 17), contents of bands 1 to 9 and 0 (page 22) can be changed. Before going to step 1 below, perform necessary settings such as frequency step (page 35), reception mode (page 36) and attenuator (page 42).

- 1 Press the **FUNC** key [24].  
[FUNC] is displayed.
- 2 Press the **MR** key [23].  
Band numbers 0 to 9 and the frequency begin blinking.

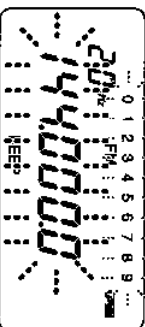

- 6 Press the **ENT** key [25].  
The frequency reading will be turned off after 1 second.
- 7 Select the band whose contents are to be entered or changed by using the correct numeric key.

- 8 Press the **ENT** key [24].  
Beep sounds twice. The frequency display shows the registered band No. for about 1 second and then returns to the initial frequency. This completes the registration.
- 3 Enter the lower limit of the frequency range with the numeric keys.  
The lower limit of the frequency range starts blinking in the frequency display.

- 4 Press the **ENT** key [25].  
The frequency reading will be turned off after 1 second.
- 5 Enter the upper limit of the frequency range with the numeric keys.  
The upper limit of the frequency range starts blinking in the frequency display.

- The specified frequency is adjusted according to the preset reception mode and frequency step, and then registered.
- Steps 3 and 5 can be reversed.
- Pressing the **CLAC** key [21] in step 3, 5 or 7 enables frequency change (page 19) or band change to be registered. Pressing the key again aborts the band registration procedure.
- If the next key input is not done for more than 10 seconds, the process is aborted and the unit returns to the state as before step 1.
- If the frequency specified with key inputs is outside the unit's reception scope, the unit beeps and displays [Error] and then returns to the state as before step 1.
- The unit can continue receiving operation while band registration process.

OTHER FUNCTIONS

OTHER FUNCTIONS

# USEFUL FUNCTIONS

Continued on next page

## Monitor Function

The monitor function enables clearer reception of a fading or interrupted signal.

**Press and hold the MONI button [4].**

As long as the button is held down, the monitor function is enabled and reception is clearer.

When the button is released, the monitor function is disabled.

- If the MONI button [4] is pressed while searching or scanning, the search or scan is suspended until the button is released.
- Do not press the MONI button [4] while adjusting squelch.

## Lamp

Lights the display and keys. The lighting can be kept turned on. The color of the display can be changed.

**Pressing the LAMP button [3] once:**

The lamp stays on for about 5 seconds. If keys are pressed while the lamp is on, it stays on for about 5 seconds after the last key is pressed.

- To turn off the lamp immediately (within 5 seconds), press the LAMP button [3].
- The PWR button [1], VOL knob [5], SQL knob [7] have no relationship with lamp lighting time.

**When the LAMP button [3] is pressed and hold for more than 1 second:**

Icons displayed and lamp is kept on.

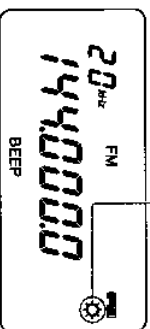

To turn off the lamp, press the LAMP button [3]. The lamp and mark [ ] are turned off.

## Changing display backlight color

The backlight color can be changed from the factory-set color (yellow-green) to orange.

**1 Press the FUNC key [2].**

**2 Press the LAMP button [3].**

The backlight changes color and lights for about 5 seconds.

- To turn off the light immediately, press the LAMP button again.
- The color of the key lamp (yellow-green) cannot be changed.

## Changing Beep Tone

A key operation is verified by beep sounds: The beep is initially enabled but can be disabled.

Key operation	Beep
When a key is pressed	Single beep
When registration completes	Double beep
Upon wrong operation	Triple beep

**1 Press the FUNC key [2].**  
[FUNC] will light.

**2 Press the numeric key 5 [5].**  
[BEEP] turns off indicating that the beep will be muted.



To enable the beep again, repeat steps 1 and 2. [BEEP] will turn on.

OTHER FUNCTIONS

OTHER FUNCTIONS

## USEFUL FUNCTIONS

(Continued on next page)

### Key Lock

Keys and DIAL knob can be disabled to avoid accidental activation. However, the PWR button, key lock release, VOL knob and SQL knob cannot be disabled.

**1** Press the FUNC key [24].  
[FUNC] will light.

**2** Press the arrow key  $\nabla$  [30].  
[LO] is displayed, indicating that the lock is activated.



To unlock, repeat steps 1 and 2.  
[LO] will be turned off.

### Attenuator Function

When there is interference, such as TV broadcasting station signals, or static, the attenuator can be used to improve reception.

**1** Press the FUNC key [24].  
[FUNC] will light.

**2** Press the numeric key 1 [11].  
[ATT] lights and the attenuator is activated.

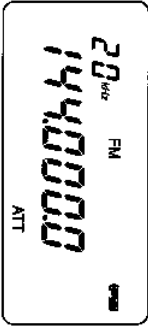

To disable the attenuator, repeat steps 1 and 2. [ATT] is turned off indicating that the attenuator is disabled.

- The attenuator decreases the gain of the circuitry by 15 dB.
- When the attenuator is enabled, reception of weak signals is not possible so use the attenuator only when it is needed.
- The attenuator can be engaged while in the VFO searching or band searching. (It can be registered to the search pass memory.)
- If the attenuator is enabled/disabled during band searching, the information on the attenuator is added to the memory for that band.
- If the attenuator is enabled/disabled while in a scan mode, the information on the attenuator is added to the memory for that channel.

### Battery Saving

This battery saving function will turn off power when no operation or no receiving duration lasts for more than 5 seconds.

Entering battery save mode

**1** Set the unit to VFO mode or channel memory read mode.  
See page 17 or 26.

**2** Select one of the following times shown below by pressing the correct numeric key (1), (2), or (3):

Key	Active time	Inactive time	Duty ratio
1	0.3s	0.3s	1:1
2	0.3s	0.9s	1:3
3	0.3s	1.5s	1:5

• Numeric key and inactive time

**3** Press the FUNC key [24].  
[FUNC] will light.

**4** Press the numeric key 4 [4].  
The receiver now enters the battery save mode and indicates the mark [SAVE] and one of 1, 2 and 3 selected in the step 2 above.

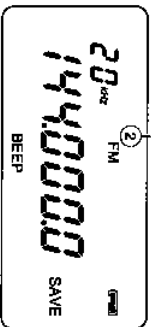

The time selected in the step 2.

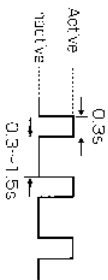

<Active time and inactive time during battery save mode>

When no operation or no receiving duration lasts for more than 5 seconds:

If this non-operation occurs while in the VFO mode or during channel memory read mode, the battery saving function is enabled.

- If the step 2 is skipped or a numeric key other than 1, 2 and 3 is pressed in the step 2, the duty ratio 1:1 will be automatically selected as the default setting.

To cancel the setting, repeat steps 3 and 4 and the mark [SAVE] will be turned off.  
Searching or scanning causes the unit to exit the battery save mode.

## OTHER FUNCTIONS

## USEFUL FUNCTIONS

### Cloning

Contents stored in the unit can be duplicated on another MVT-7300EU.

- 1 Connect the EAR socket on the unit to that on the to-be-clone MVT-7300EU through a  $\phi$ 3.5 stereo plug connection cable with both units turned off.

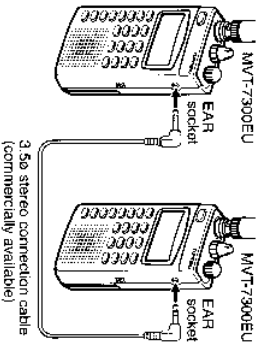

- 2 Turn on both units and set them to VFO mode.
- 3 On each unit, press the keys shown below in that order.

Now the both units are in cloning mode.

The display reads [Pc Int] in the frequency display.

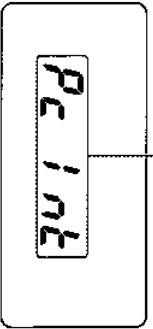

- 4 Transfer all data store in the memory: on the original unit, press the numeric key 1  and ENT key .

- The display on both units indicate address of memory location of data being transferred.
- After transmitting all the necessary data, the original unit displays [PcInt]. The receiving unit turns off, displaying [CLEAR] for 1 second and then the current time.
- The data transfer takes about 6 minutes depending on the size of the data copied.
- The cloning operation cannot be interrupted. No key operation is accepted during data transfer.
- If the data transfer fails, display shows [Error] for several seconds and then returns to [PcInt]. Check connections especially at the EAR sockets and then repeat the procedure with step 1.

- 5 Turn off original MVT-7300EU. Disconnect the connection cable from both units.

#### CAUTION

Note that in step 4, if the wrong numeric key 6 or 7 is pressed instead of "1" key, the following will result (also refer to page 50):

Key operation on source unit	Source unit	Clone unit
<input type="button" value="9"/> <input type="button" value="ENT"/>	—	All memory erased
<input type="button" value="7"/> <input type="button" value="ENT"/>	All memory erased	—

## TIMER FUNCTIONS

(Continued on next page)

### Timer Function

While power is off, the unit displays the time of day.

The unit also shows the time as the ENT key  is pressed in the VFO mode while the frequency is being displayed.

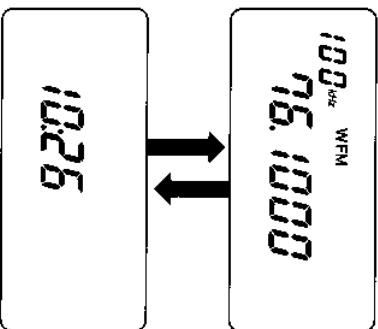

The ENT key  is pressed in the VFO mode while the frequency is being displayed; the current time will be displayed for 5 seconds.

### Setting Mode

The timer can be used to issue alarm or to turn on or off the unit.

These times are set in the setting mode.

- 1 Enter the VFO mode.  
See page 17.

- 2 Press the FUNC key . [FUNC] will light.

- 3 Press the ENT key . The unit is now in the setting mode and displays the time of day.



Set alarm or turn on and off time, or adjust the clock.

#### Precautions:

- During setting procedure a step must be followed by the next step within 10 seconds.
- To cancel the setting mode, press C/CA key . The unit returns to the VFO mode.

## OTHER FUNCTIONS

## TIMER FUNCTIONS

(Continued on next page)

### Setting the Time of Day

- 1 Enter the setting mode.  
See page 45.
- 2 Using the DIAL knob [8], select the clock setting mode.

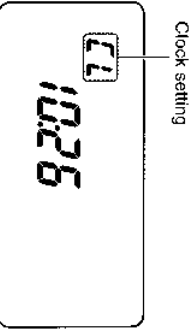

- 3 Press the ENT key [25].  
The hour field blinks.

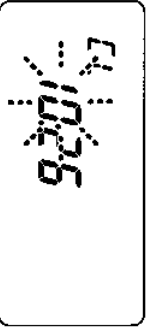

- 4 Set the clock to the current hour by turning the DIAL knob [8].

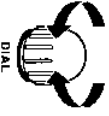

- 5 Press the ENT key [25].  
The minute field blinks.

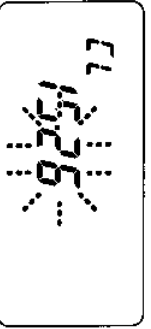

- 6 Set the clock to the current minute by turning the DIAL knob [8].



- 7 Press the ENT key [25].

A beep sounds twice indicating the end of time setting.  
The unit displays the time for 1 second and goes to the VFO mode.

Pressing the C/AC key [27] before step 7 aborts the setting and returns to the VFO mode.

• Each step except step 7 must be followed by the next step within 10 seconds. Otherwise, the procedure will be aborted and the unit will return to the VFO mode.

The MVT-7300EU internal clock may vary about 3 minutes per month. Adjust the clock as necessary.

### Setting Alarm

The alarm will sound beeps at the specified time even if the unit is off.

- 1 Enter the setting mode.  
See page 45.
- 2 Using the DIAL knob [8], select the alarm setting mode.

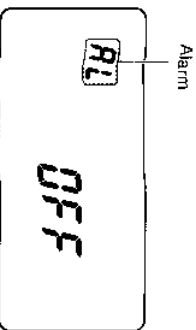

- 3 Press the ENT key [25].  
[OFF (or ON)] will blink.

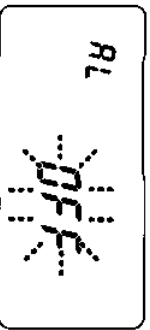

- 4 Turn the DIAL knob [8] so that [ON (or OFF)] is displayed.

- 5 Press the ENT key [25].  
Hour field blinks.

If [OFF] has been selected in the step 4, short beep sounds twice, indicating the end of the setting.

- 6 To change the hour, select by turning the DIAL knob [8].

- 7 Press the ENT key [25].  
Minute field blinks.

- 8 Set the minute value by turning the DIAL knob [8].

- 9 Press the ENT key [25].

Short beep sounds twice indicating that the set value is accepted.

The display shows the new time for about 1 second and then returns to show VFO mode.

To abort the alarm setting procedure, press the C/AC key [27]. The receiver returns back to the VFO mode.

• The setting procedure must be performed within 10 seconds, otherwise the procedure will be aborted and the unit will return to the VFO mode.

OTHER FUNCTIONS

OTHER FUNCTIONS

## TIMER FUNCTIONS

### Setting ON Timer

Once set, the timer turns on power to the receiver on the specified time.

- 1 Enter the setting mode.  
See page 45.
- 2 Select ON timer by turning the DIAL knob [8].  
[OFF (or ON)] will appear on the display.  
ON timer
- 3 Press the ENT key [25].  
[OFF (or ON)] will blink.
- 4 Turn the DIAL knob [8] so that ON timer [ON (or OFF)] is displayed.
- 5 Press the ENT key [25].  
Hour field blinks.
- 6 To change the hour, select by turning the DIAL knob [8].
- 7 Press the ENT key [25].  
Minute field blinks.
- 8 Set the minute field by turning the DIAL knob [8].
- 9 Press the ENT key [25].  
Short beep sounds twice indicating that the set value is accepted.

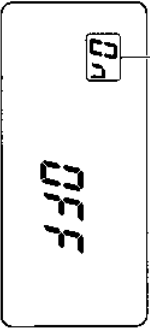

- 3 Press the ENT key [25].  
[OFF (or ON)] will blink.



- 4 Turn the DIAL knob [8] so that ON timer [ON (or OFF)] is displayed.

- 5 Press the ENT key [25].  
Hour field blinks.

If [OFF] has been selected in the step 4, short beep sounds twice, indicating the end of the setting.

OTHER FUNCTIONS

### Setting OFF Timer

Once set, the timer turns off power to the receiver after the specified time. This is a one-time setting. That is, this function should be set every time as necessary.

- 1 Enter the setting mode.  
See page 45.
- 2 Select OFF timer by turning the DIAL knob [8].  
[OFF (or ON)] will appear on the display.  
OFF timer
- 3 Press the ENT key [25].  
[OFF (or ON)] will blink.
- 4 Turn the DIAL knob [8] so that OFF timer [ON (or OFF)] is displayed.
- 5 Press the ENT key [25].  
Minutes (time to turn off) blinks.
- 6 To change the time to off, select value between 1 minute and 180 minutes by turning the DIAL knob [8].
- 7 Press the ENT key [25].  
Short beep sounds twice indicating that the set value is accepted.



- 3 Press the ENT key [25].  
[OFF (or ON)] will blink.

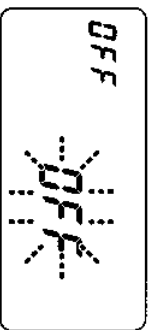

- 4 Turn the DIAL knob [8] so that OFF timer [ON (or OFF)] is displayed.

- 5 Press the ENT key [25].  
Minutes (time to turn off) blinks.

If [OFF] has been selected in the step 4, short beep sounds twice, indicating the end of the setting.

The display shows the new time for about 1 second and then returns to VFO mode and display shows [TIMER].

To abort the alarm setting procedure, press the C/AC key [27].

• The setting procedure must be performed within 10 seconds. Otherwise, the procedure will be aborted and the unit will return to the VFO mode.

OTHER FUNCTIONS



# INITIALIZATION

## Reset Function (Memory All Clear)

This function clears memory and returns to the default configuration.

**1** Enter the clone mode (see page 44).

However, the EAR socket should be left unconnected and [Pcint] should be displayed in the frequency display.

**2** To erase all memory contents: Press the numeric key **7** [7] and **ENT** key [25].



Display turns off indicating the start of the memory erasing process and then will show [E L E R-] for several seconds at the end of the erasure process and the receiver turns off power. The display then shows clock time.



\* To erase contents of memory in the MVT-7300EU connected to an MVT-7300EU through a  $\phi$ 3.5 plug cable (for cloning), follow the procedure on page 44.

### Settings

Function	Default	Page
Operating Mode*	VFO mode : 144.000.00MHz	16
BEEP	ON	41
KEY LOCK	OFF	42
SKIP	OFF	38
AW	OFF	38
PRI	OFF	34
ATT	OFF	42
SCR	OFF	37
Channel Memory	Blank	25
PRI Channel Memory	350.1MHz	34
Search Pass Memory	Blank	23
Current Channel Number	000CH	26

\* Factory settings: Frequency step 20 kHz, reception mode FM

\* Search band Initial settings: factory default settings as shown on page 22.

# TROUBLESHOOTING GUIDE

Before requesting service for your MVT-7300EU, we ask that you check the following conditions. If the table is unable to assist you, then contact your shop purchased.

Problem	Possible cause	Remedy
Nothing appears on the display	The battery is exhausted.	Replace the battery (page 15).
Sometimes "PCH" is displayed	The priority function is activated.	Disable the priority function (page 34).
"P" is blinking.	The search pass memory is being accessed.	Abort search pass memory access (page 23).
Reception is interrupted.	Poor squelch adjustment. The signal is too weak.	Readjust the squelch (page 16). Press the MONI button (page 40).
Received sound cannot be correctly reproduced.	The attenuator is activated. Scramble is activated.	Disable the attenuator (page 42). Turn off the scrambling function (page 37).
Nothing happens when key is pressed.	The key lock is on.	Turn off key lock (page 42).
Frequency input is not accepted.	The entered frequency is outside the unit's reception range.	Input a valid frequency.
Cannot search	Poor squelch adjustment. The MONI button is being held down.	Readjust the squelch (page 16). Release the MONI button (page 40).
Cannot scan	Poor squelch adjustment. The MONI button is being held down. All channels are designated scan pass. No channels are stored in channel memory.	Readjust the squelch (page 16). Release the MONI button (page 40). Cancel scan pass designation (page 27). Store some channels in channel memory (page 25).

# SPECIFICATIONS

Frequency range(MHz) : 0.531~1320MHz(display reading range: 0.1~1320 MHz)  
 Reception mode : FM,W-FM,N.AM,AM,LSB,USB,CW  
 Frequency step (Hz) : 50,100,1k,5k,6.25k,8.33k,9k,10k,12.5k,15k,20k,  
 25k,30k,50k,100k,125k  
 0.531MHz~2.0MHz  
 Sensitivity : AM : 5.0 $\mu$ V or less at SN 10dB  
 2.0MHz~30MHz  
 AM : 2.5 $\mu$ V or less at SN 10dB  
 SSB : 1.0 $\mu$ V or less at SN 10dB  
 30.0MHz~470.0MHz  
 FM : 0.5 $\mu$ V or less at SINAD 12dB  
 W-FM : 1.0 $\mu$ V or less at SINAD 12dB  
 AM : 1.0 $\mu$ V or less at SN 10dB  
 SSB : 0.5 $\mu$ V or less at SN 10dB  
 470.0MHz~830.0MHz  
 FM : 0.75 $\mu$ V or less at SINAD 12dB  
 W-FM : 1.5 $\mu$ V or less at SINAD 12dB  
 830.0MHz~1000.0MHz  
 FM : 0.75 $\mu$ V or less at SINAD 12dB  
 1000.0MHz~1320.0MHz  
 FM : 1.0 $\mu$ V or less at SINAD 12dB

Channel memory : 1000ch  
 Search pass memory : 500ch  
 Priority channel memory : 1ch  
 Bank memory : 10BANK  
 Channels per bank : 100ch/BANK  
 Programmed channels : 10ch/BANK(100ch)  
 Band memory : 10BAND  
 Search speed : 30STEP/sec  
 Scan speed : 30 channels/sec (max.)  
 Impedance and antenna connection : 50 $\Omega$ /BNC  
 Power supply : 4.5 V (1.5 V dry cell x 3)  
 Low frequency output : External power 12 VDC (AC adaptor, car battery)  
 Current consumption (at 4.5 V) : Max. output power 180 mA (standard)  
 Standby 105 mA (standard)  
 0-50 $^{\circ}$ C (AC adaptor: 0-40 $^{\circ}$ C)  
 Guaranteed operating temperature : 60.0 (W) x 120.0 (H) x 32.0 (D) mm  
 External dimensions (projection excluded)  
 Weight : Approx. 310 g (incl. Antenna and batteries)  
 Optional : Suit case (OP-73)  
 Accessories included : Cigarette lighter plug cord (OP-5)  
 : Telescopic antenna, Belt clip, Earphones

## USEFUL INFORMATION

52 \* Number of available steps depend on the selected reception mode.  
 ※ Specifications subject to change without notice.

# QUICK REFERENCE CHARTS

(continued on next page)



## 1 Basic Operation

### Tuning ... WFO Mode

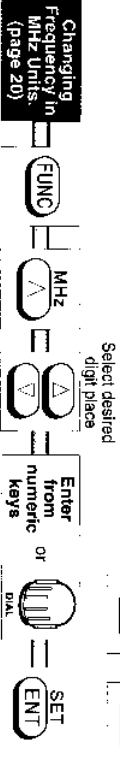
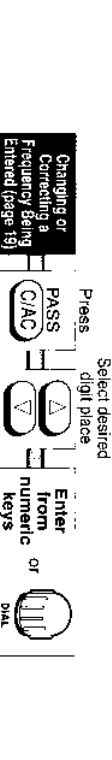
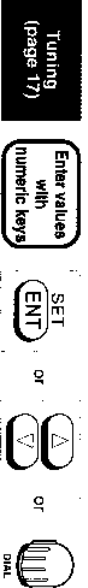

### Tuning ... Search Mode



## USEFUL INFORMATION

## QUICK REFERENCE CHARTS

(Continued on next page)

### Tuning ... Band Search

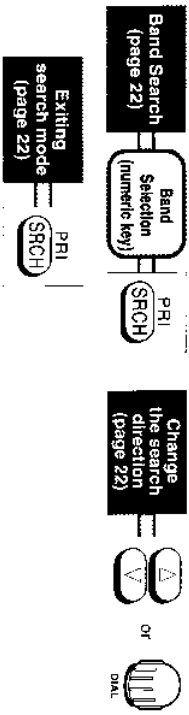

### Search Pass Memory

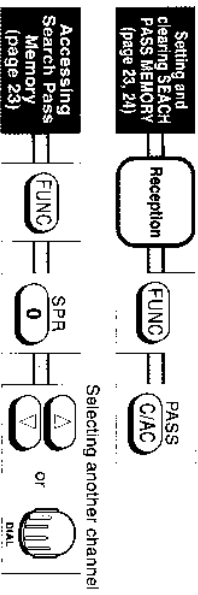

## 2 Memory and Scanning

### Channel Memory

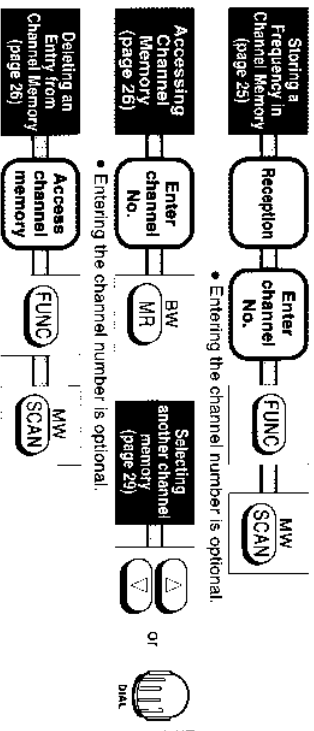

### Scan Pass



### Scanning ... Sequential Scanning

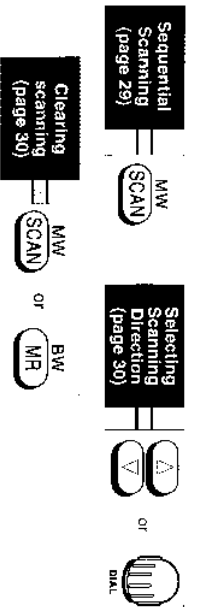

### Bank Scanning



### Mode Scanning ... Reception mode should have been selected in VFO mode

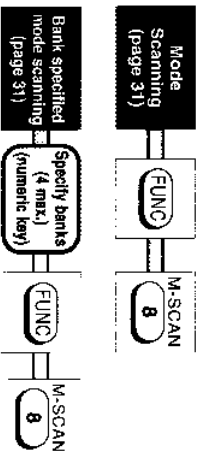

# QUICK REFERENCE CHARTS

Continued on next page

## Programmed Scanning



## Priority Scanning



## 3 Other Functions

### Changing frequency step

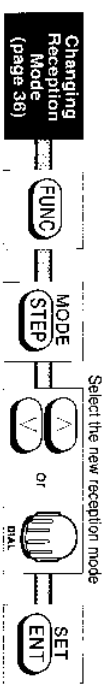
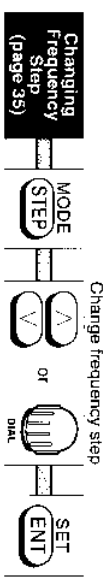

## Receiving Scrambled Communications

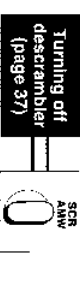

## Optional Functions for Searching and Scanning

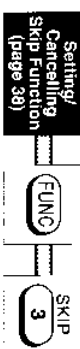
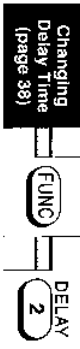

### Changing Contents of Search Band ... select frequency step and reception mode beforehand

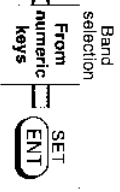
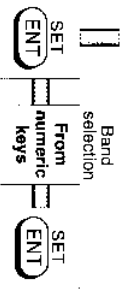
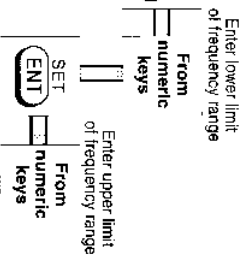
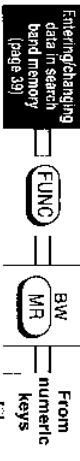

## QUICK REFERENCE CHARTS

### Convenient Features

Monitor Function  
(Disabling Squelch)  
(page 40)



- \* Cancels squelch while being depressed
- Functions differently while in duplex mode.

Lamp ON/OFF  
Function  
(page 40)



Press once

Lamp ON  
Function  
(page 40)



Press and hold for more than 1 second.

Changing display  
background color  
(page 41)



- Toggles between yellow-green and orange.

Changing Beep Tone  
(page 41)



Key lock/  
unlock  
(page 42)



Setting/  
resetting  
attenuator  
(page 42)



### Changing Battery Save Time ... only while in VFO mode, channel memory reading

Select the save time

Changing battery save  
time  
(page 43)



Cloning VFO  
(page 44)



On both units

Source MVT-7300EU

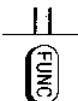

Transferring of all stored data  
(page 44)



### Timer Setting ... can be set only in VFO mode

Setting timer  
functions  
(page 45)



- In the set mode, select time-related function.

### Setting the Time of Day (page 46)

Select clock setting



### Setting Alarm (page 47)

Select alarm setting

Select alarm ON or OFF

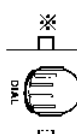

### Setting ON Timer (page 48)

Select ON timer setting

Select ON timer ON or OFF

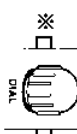

### Setting OFF Timer (page 49)

Select OFF timer setting

Select OFF timer ON or OFF

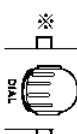

Displaying clock during reception  
(page 45)



- While power is on, time is displayed only in the VFO mode and for about 5 seconds.
- While power is off, time is always displayed.

Reset <clearing all memory>  
(page 50)

